

POLYMER UTILITY CART: myCart™ Series

User-Friendly: Ergonomic handle and additional legroom puts more distance between the shelves and you. You can push the cart more freely without hitting your shins and feet off the cart.

Convenient: The utility tray is roomy enough to store every day objects. It offers 2x the amount of space than traditional utility carts; which allows for objects to fit in comfortably.

Personalized: Each cart comes with two labels for easy identification.

Ultimate Cleanability: Smooth polymer shelf surfaces with contoured edges are designed to resist staining and wipe clean easily.

Corrosion-Proof Shelves: All-polymer shelves will never corrode.

Sturdy construction: Impact resistant shelves are designed to withstand daily abuse.

Weight capacities evenly distributed:

MY1627 and MY2030 models: 150lbs. (68kg) per shelf, not to exceed 300lb (136kg) on a 2-shelf cart and 400 lb. (181kg) on a 3-shelf cart.

MY2636 Models: 200lbs. (90kg) per shelf, not to exceed 400 lb. (181kg) on a 2-shelf cart and 500 lbs. (227kg) on a 3-shelf cart.

Contains Spills: 7/16" (11mm) ship's edge retains small spills and prevents items from sliding off during transport.

Specific Models with Microban® product protection: The blue MyCart has built in Microban® product protection. This inhibits the growth of bacteria, mold, mildew, and fungi that cause odors, stains, and product degradation.

Attractive Aesthetics allow for use in a variety of applications.

2-tier and 3-tier models available

Easy-to-Adjust: Optional center shelf adjusts on 1" (25mm) increments.

Easy, No-Tool Assembly: Ships knocked down.

myCart™ Series is NSF listed

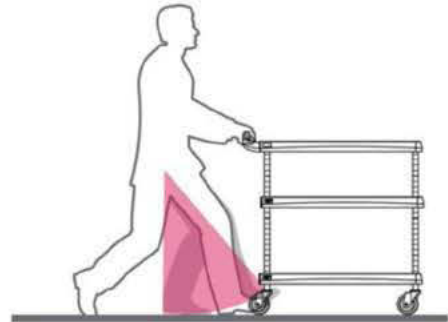

Blue



Black



Gray



*MICROBAN® and the MICROBAN® symbol are registered trademarks of the Microban® Products Company, Huntersville, NC.

POLYMER UTILITY CART: myCart™ Series



Short Form Specs – Base models

Cart, Utility, consisting of at least 2 high-density polyethylene, injection-molded shelves and 4 chrome-plated posts. Handle shelf will have an integrated utility tray with a base width of 1.8-2.2" (46-56mm) and covered corners. Flat shelf will have a built in 3" (76mm) cutaway. All shelves will have a built-in 7/16" (11mm) deep ship's edge around the perimeter. 2-shelf cart design is such that user may add an intermediate shelf if deemed necessary that adjusts on 1" (25mm) increments. Cart will include two nominal 4.625"Lx.88"H (117.475 x 22.352 mm) labels for easy identification.

- **1627 and 2030 models:** Roll on four 4" (102mm) diameter thermoplastic, mark-resistant swivel/stem casters.
- **2636 models:** Roll on four 5" (127mm) diameter thermoplastic, mark-resistant swivel/stem casters.
- **Blue models:** Have built-in Microban® antimicrobial product protection. Microban® antimicrobial product protection will inhibit the growth of bacteria, mold, mildew, and fungus that cause odors and product degradation.
- **My 1627 Upgraded Model:** Cart, Utility, consisting of at least two high-density polyethylene, injection-molded shelves with Microban® product protection and four type 304 stainless steel posts.

Construction

- **Continuous Usage Temperature:** -20/120°F (-29/49°C)
- **Carts are not intended for cart wash applications**
- **Casters**
 - 4" (102mm) swivel caster: Thermoplastic, non-marking gray tread. Plated horn and axle.
Replacement part: RPBC4M-4, bag of four.
 - 5" (127mm) swivel caster: Resilient rubber material, plated horn and axle.
Replacement part: 5M, sold individually.

Configurations

- 2-tier and 3-tier models
- MY1627 and MY2030 Base Model Specs: Chrome posts, 4" (102mm) non-marking swivel casters.
- MY2636 Base Model Specs: Chrome posts, 5" (127mm) swivel resilient rubber casters
- MY1627 Upgraded Model Specs: Blue shelves with built-in Microban® antimicrobial product protection, type 304 stainless steel posts, 4" (102mm) non-marking swivel casters.

Actual Width/Length/Height including the handle		Description	Posts	Load Rating per Cart		Approx. Pkd. Wt.		Cat. No. Gray	Cat. No Black	Cat. No Blue with antimicrobial
(in.)	(mm)			(lbs.)	(kg)	(lbs.)	(kg)			
18 5/16 x 31 1/2 x 35 1/2	465.2x800.1x901.7	2-shelf base model	chrome-plated	300 lbs.	136 kg	28.5	12.93	MY1627-24G	MY1627-24BL	MY1627-24BU
18 5/16 x 31 1/2 x 35 1/2	465.2x800.1x901.7	3-shelf base model	chrome-plated	400 lbs.	181 kg	34	15.42	MY1627-34G	MY1627-34BL	MY1627-34BU
23 7/16 x 34 3/8 x 35 1/2	595.3x873.3x901.7	2-shelf base model	chrome-plated	300 lbs.	136 kg	33	14.97	MY2030-24G	MY2030-24BL	MY2030-24BU
23 7/16 x 34 3/8 x 35 1/2	595.3x873.3x901.7	3-shelf base model	chrome-plated	400 lbs.	181 kg	41.5	18.82	MY2030-34G	MY2030-34BL	MY2030-34BU
27 11/16 x 40 1/4 x 36 7/8	703.3x1022.4x936.6	2-shelf base model	chrome-plated	400 lbs.	181 kg	40	18.14	MY2636-25G	MY2636-25BL	MY2636-25BU
27 11/16 x 40 1/4 x 36 7/8	703.3x1022.4x936.6	3-shelf base model	chrome-plated	500 lbs.	227 kg	51	23.13	MY2636-35G	MY2636-35BL	MY2636-35BU
18 5/16 x 31 1/2 x 35 1/2	465.2x800.1x901.7	2-shelf cart, upgrade	stainless steel	300 lbs.	136 kg	28.5	12.93	-	-	MY1627-24BU-SS
18 5/16 x 31 1/2 x 35 1/2	465.2x800.1x901.7	3-shelf cart, upgrade	stainless steel	400 lbs.	181 kg	34	15.42	-	-	MY1627-34BU-SS

Additional Intermediate Shelves

Width/Length		Approx. Pkd. Wt		Cat. No. Gray	Cat. No Black	Cat. No Blue with antimicrobial
(in.)	(mm)	(lbs.)	(kg)			
18 5/16 x 28 5/16	465.2x719.2	7.5	3.40	MY1627-FG	MY1627-FBL	MY1627-FBU
23 7/16 x 31 1/4	595.3x793.4	9.2	4.17	MY2030-FG	MY2030-FBL	MY2030-FBU
27 11/16 x 37 1/16	703.3x941.4	12.8	5.81	MY2636-FG	MY2636-FBL	MY2636-FBU



Item# _____

Job _____



POLYMER UTILITY CART: myCart™ Series

Dimensions

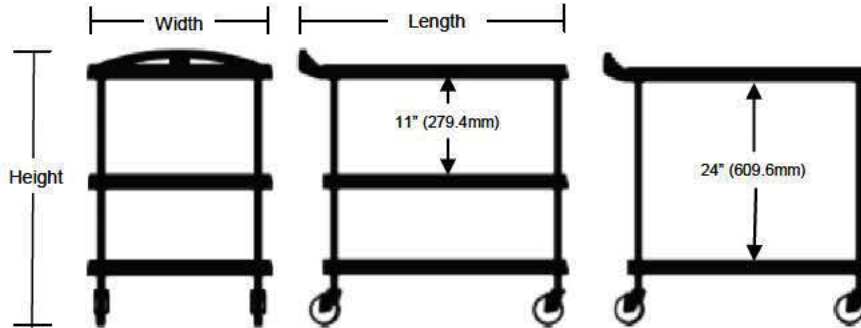

MY1627

- Easy-grip handle and utility tray
- Small footprint for tight spaces
- Accommodates Metro tote boxes and ISO totes



18-5/16" (465.2mm)

31-1/2"
(800.1mm)

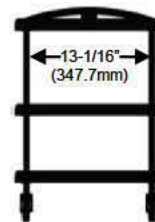

13-1/16"
(347.7mm)

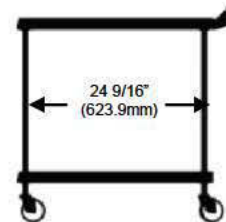

24 9/16"
(623.9mm)

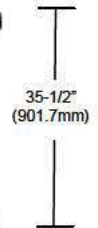

35-1/2"
(901.7mm)

MY2030

- Cart handle has built-in recessed support channels to manage odd shaped items
- Sized for standard racks
 - (1) Glass/dish rack
 - (2) milk crates
 - (2) bus box [on top shelf
 - (1) bus box + (1) silverware tote [on mid/bottom shelf]



23-7/16" (595.3mm)

34-3/8"
(873.1mm)

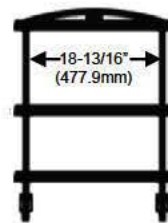

18-13/16"
(477.9mm)

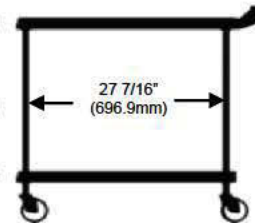

27 7/16"
(696.9mm)

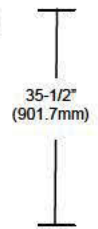

35-1/2"
(901.7mm)

MY2636

- Top shelf can accommodate:
 - (2) nominal 18x26" (457x660mm) polycarbonate totes side by side
 - (2) Metro totes measuring 17-1/2 x 22-1/2" (445x571mm) side by side
- Cart handle has built in slot to hold scanners



See cut list for details.
Material: 2625 White imprinted polypropylene with 2022 Clear self-lubricating wheels.
Construction: untextured HDPE
Weight: 11.5 lbs (5.2 kg)
Colors: Grey - PM5 412, Light blue - PM5 2109
Slips: 1,000 per roll x 300000 sq ft per roll



27-11/16" (703.3mm)

40-1/4"
(1022.4mm)

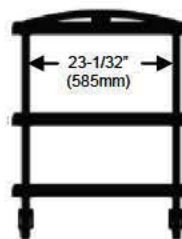

23-1/32"
(585mm)

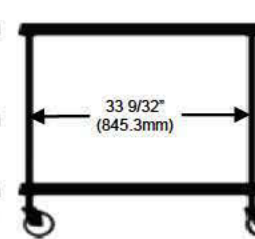

33 9/32"
(845.3mm)



36-7/8"
(936.6mm)

Personalization Label:

- Each cart comes with two nominal 4.625"Lx.88"H (117.475 x 22.352 mm) labels for easy identification.



12.29

Accessories



Model No.	Description	Fits Cart	Width/Height/Depth		Approx. Pkd/ Wt.	
			(in.)	(mm)	(lbs.)	(kg)
MYWB1	Wastebasket (including holder)	MY1627	17 ⁷ / ₈ x 16 ¹ / ₄ x 14 ³ / ₄	454x413x375	5.7	2.5
MYWB2	Wastebasket (including holder)	MY2030	23 x 16 ¹ / ₄ x 14 ³ / ₄	584x413x375	5.8	2.6
MF222	Wastebasket Only	MY1627, MY230	14 ³ / ₈ x 15 ³ / ₈ x 10 ³ / ₈	365x391x264	2.8	1.3
MYUB1	Utility Bin (including holder)	MY1627	17 ⁷ / ₈ x 7 x 15 ¹ / ₄	454x178x387	5	2.2
MYUB2	Utility Bin (including holder)	MY2030	23 x 7 x 15 ¹ / ₄	584x178x387	5.1	2.3
UB1	Utility Bin Only	MY1627, MY230	16 ³ / ₈ x 6 x 11	416x152x279	2	0.9

POLYMER UTILITY CART: myCart™ Series



Waste Basket

Specifications
Bin-ABS Thermoplastic
Wastebasket—Polythylene



Utility Bin



Problem Solver
PO Box 1119
Bayshore, NY 11706
631-300-9596
www.metrowire.com

